



INSTALLER'S MANUAL & OWNER'S GUIDE

Smart Electric Water Heater

Note: For full functionality, you must have continuous power supply and Wi-Fi reception at the water heater's location.



Download the Thermann Control App for water heater configuration, scheduling & mode selection.

Models

80THMW118 | 80THMW124 | 80THMW124P | 80THMW130
125THMW118 | 125THMW124 | 125THMW124P | 125THMW130
160THMW118 | 160THMW124 | 160THMW124P | | 160THMW130
250THMW118 | 250THMW124 | 250THMW124P | 250THMW130
315THMW118 | 315THMW124 | 315THMW124P | 315THMW130
400THMW124 | 400THMW124P | 400THMW124PH | 400THMW130

Note - an 'H' at the end of the model number indicates that the water heater has been pre-fitted with a hard-water anode (available in all models).



IMPORTANT SAFETY INFORMATION

WARNING - THIS APPLIANCE MAY DELIVER WATER AT HIGH TEMPERATURE. REFER TO THE PLUMBING CODE OF AUSTRALIA (PCA), LOCAL REQUIREMENTS AND INSTALLATION INSTRUCTIONS TO DETERMINE IF ADDITIONAL DELIVERY TEMPERATURE CONTROL IS REQUIRED.

WARNING - FOR CONTINUED SAFETY OF THIS APPLIANCE IT MUST BE INSTALLED, OPERATED AND MAINTAINED IN ACCORDANCE WITH THE MANUFACTURER'S INSTRUCTIONS.

This water heater is not intended for use by persons (including children) with reduced physical, sensory or mental capabilities, or lack of experience and knowledge, unless they have been given supervision or instruction concerning use of the water heater by a person responsible for their safety.

Children should be supervised to ensure they do not interfere with the water heater. Ensure animals are supervised so they do not interfere with the water heater

DO NOT STORE CHEMICALS OR FLAMMABLE MATERIALS, OR SPRAY AEROSOLS NEAR THIS WATER HEATER.

DO NOT STORE ANY FLAMMABLE OR COMBUSTIBLE MATERIALS ON OR WITHIN 1 METRE OF THE WATER HEATER.

DO NOT PLACE ARTICLES ON OR AGAINST THE WATER HEATER

DO NOT MODIFY THIS WATER HEATER.

DO NOT OPERATE THE WATER HEATER WITH ANY PANELS OR COVERS REMOVED.

If the water heater is not used for two weeks or more, a quantity of hydrogen (which is highly flammable) may accumulate inside the water heater tank.

To dissipate this gas safely it is recommended that a hot tap be turned on for several minutes at a sink, basin or bath, but not a dishwasher, clothes washer or other appliance.

During this procedure there must be no smoking, open flame or any other electrical appliance operating nearby. If hydrogen is discharged through the tap, it will probably make a sound similar to air escaping

RELIEF VALVE:

The Pressure & Temperature Relief (PTR) valve must be installed directly into the RP $\frac{1}{2}$ " (DN15) socket marked "RELIEF VALVE".

The valve must not be tampered with or removed. The water heater must not be operated unless this valve is fitted and in working order.

The drain line from the PTR Valve must be installed in a continuously downward direction in a frost-free environment.

IMPORTANT SAFETY INFORMATION

The PTR Valve is to be operated regularly to remove lime deposits and to verify it is not blocked. The drain line fitted to the PTR Valve must be left open to the atmosphere.

DANGER: FAILURE TO OPERATE THE PTR VALVE EASING LEVER AT LEAST ONCE EVERY SIX MONTHS MAY RESULT IN THE WATER HEATER EXPLODING. CONTINUOUS LEAKAGE OF WATER FROM THE VALVE MAY INDICATE A PROBLEM WITH THE WATER HEATER.

The PTR Valve should be checked by a licensed tradesperson for adequate performance, or replaced at intervals not exceeding 5 years, or less in areas where local regulations apply.

It is normal for water to drip from the drain line fitted to the PTR Valve during heating cycles.

Continuous leakage of water from the PTR Valve may indicate a problem with the water heater. This may be caused by excessive water supply pressure, a faulty PTR Valve or a faulty thermostat.

Turn off the water heater and contact Customer Service

- 1300 412 612 (Australia);
- 0800 081 909 or contact your local Reece branch (New Zealand).

OVER-TEMPERATURE ENERGY CUT-OUT:

The operation of the over-temperature energy cut-out indicates a possibly dangerous situation. Do NOT reset the over-temperature energy cut-out until the water heater has been serviced by a licensed tradesperson.

ELECTRICAL SAFETY:

This water heater is designed for single phase 230 - 240V A.C. supply only. The electrical connection must comply with Local Supply Authority Regulations and AS/NZS 3000 (known as the Wiring Rules). A means for disconnection must be incorporated in the fixed wiring in accordance with the Wiring Rules.

Any electrical covers should be removed only by a licensed tradesperson, and only after the electrical supply to the water heater has been isolated.

When the supply wiring has been connected, ensure the wires are kept lower than the terminal block.

Excess wire is not to be looped close to the thermostat or tank.

In addition to the Pressure & Temperature Relief Valve, electric storage water heaters are fitted with a combination thermostat and over-temperature energy cut-out.

Where applicable, if the supply cord is damaged, it must be replaced by the manufacturer, an authorised service agent, or similarly qualified persons in order to avoid a hazard.

IMPORTANT SAFETY INFORMATION

This device must not be tampered with or removed. Replacement of this device must only be carried out by a licensed tradesperson or the manufacturer.

The water heater must not be operated unless this device is fitted and in working order.

The Smart Electric water heater should never be powered by an extension lead.

COLD WATER CONNECTION:

The water heater is intended to be permanently connected to the water supply main, and not connected by a hose-set.

This water heater is designed for direct connection to water supply pressure up to 800 kPa.

Where the mains pressure can exceed or fluctuate beyond this pressure, a pressure reducing valve must be fitted in the cold-water inlet supply.

Instructions explaining how the water heater can be drained can be found on page 4.

INSTALLATION REQUIREMENTS

IMPORTANT - your Wi-Fi signal must be able to be received at the water heater location. It is possible that you may require Wi-Fi extenders. If you can't receive Wi-Fi at the water heater's location, you may be able to connect with a temporary hot spot, but you will only be able to control the heater when network is available and may not benefit from the full functionality. Full functionality requires a Wi-Fi connection at the water heater's location.

General:

This water heater must be installed by a licensed tradesperson, and in accordance with:

- In Australia, the Plumbing Code of Australia (PCA). The products comply with the lead-free requirements of the national construction code, Volume Three;
- In New Zealand, Clause G12 of the New Zealand Building Code (NZBC);
- AS/NZS 3000 Electrical Installations (known as the Australian / New Zealand Wiring Rules); and
- Local authority regulations.

Outside Australia and New Zealand, please refer to local plumbing and building codes and regulations.

Failure to comply with these requirements may affect the warranty.

IMPORTANT SAFETY INFORMATION

AS/NZS 3500.4 Plumbing and Drainage – Heated Water Services provides a Deemed-to-Satisfy Solution for the PCA and a Verification Method for Clause G12 of the NZBC. Other methods of compliance are available. It's recommended that installations conform with AS/NZS 3500.4.

Note for Victoria:

This water heater must be installed by a licensed person as required by the Victorian Building Act (1993).

Only a licensed person will provide a compliance certificate, showing that the work complies with all the relevant Standards. Only a licensed person will have insurance protecting their workmanship.

Pool Heating:

This water heater must **not** be used for pool heating.

Location:

The water heater should be located as close as possible to the most frequently used hot water outlet.

Ensure the compliance plate and associated warnings are clearly visible. The water heater must be accessible without the use of a ladder or scaffold. Adequate clearance must be available for service to the element, thermostat, relief valve and anode. All models are equipped with a sacrificial anode, allow half of the height of the water heater to provide access through the top cover.

Electric storage water heaters may be installed indoors. A properly drained safe tray must be installed where property damage could occur from water spillage. Refer to AS/NZS 3500.4 for further information.

Refer to local regulations before installing the water heater in a roof space.

Water Heater Support:

The water heater must be installed on a flat, solid supporting surface. The pipework must not be used to support the water heater.

Where the water heater is subjected to wet conditions, a plinth should be installed under the water heater.

CONTENTS

Important Safety Information	i
Installation Requirements	iii
Plumbing Connections	1
Filling and Draining	4
Specifications	5
Electrical Connection	6
Wiring Diagram	8
Water Heater Modes	9
Thermann Control App	12
Additional Features	17
System Maintenance	18
Considering a Service Call	19
Warranty	23
Handover to Customer	28

Specifications and materials may change without notice.
Effective for all Thermann Smart Electric Water Heaters manufactured
and sold after 1st April 2024.

PLUMBING CONNECTIONS

Relief Valve:

The Pressure & Temperature Relief (PTR) Valve is supplied in a carton/bag attached to the water heater.

Discard the packaging containing the PTR Valve and brass plugs.

The PTR Valve rating depends on the size of the water heater. See Specifications on page 5 for details.

The PTR Valve rating is also shown on the compliance plate. The PTR Valve must be installed directly into the RP $\frac{1}{2}$ " (DN15) socket marked "RELIEF VALVE" at the top of the water heater. Ensure that a sealing material is applied to the PTR Valve to prevent water leaks.

The drain line from the PTR Valve must be made of copper and run-in accordance with the requirements of AS/NZS 3500.4. It must be installed in a continuously downward direction in a frost-free environment.

The PTR Valve and its drain line must not be sealed or blocked. Generally, a separate drain line must be run for the valve although it may be joined with the drain line from the expansion control valve under certain circumstances.

The PTR valve must be insulated with the PTR insulation supplied with the heater.

Care must be taken when attaching pipe saddles to the water heater. Self-drilling screws no longer than 12 mm are recommended.

It is normal for the valve to leak a small amount of water during heating cycles.

The PTR Valve is not intended to enable connection of the water heater to supplementary energy sources such as solar panels or slow combustion stoves. Refer to AS/NZS 3500.4 for guidance on these types of installations.

Hot Water Connection:

The hot water pipe is to be connected to a RP $\frac{3}{4}$ " (DN20) socket marked "OUTLET" at the top of the water heater.

On dual handed models, the unused socket marked "OUTLET" is to be plugged with one of the brass plugs supplied. Ensure that a sealing material is applied to the brass plug to prevent water leaks.

It is recommended that all hot water pipes are insulated. Hot water pipes installed outdoors should be insulated with UV stabilised insulation.

Plastic pipes or fittings shall not be used within 1 metre of the outlet although they may be used downstream of a temperature control valve.

Refer to AS/NZS 3500.4 for further details.

PLUMBING CONNECTIONS

Temperature Protection:

Water heaters can produce very hot water. To reduce the risk of scald injury, it is mandatory under the requirements of AS/NZS 3500.4 that an approved temperature control device is fitted to the hot water supply to outlets used primarily for personal hygiene. This device should be checked at regular intervals to ensure its operation and settings remain correct.

Water Supply:

This water heater has been manufactured to suit the water conditions of most Australian and New Zealand metropolitan supplies.

Please note certain water supplies can have a detrimental effect on the water heater and its life expectancy. If you are unsure about the water supply, you can obtain information from the local water supply authority.

The water heater is designed for use in areas where the Total Dissolved Solids (TDS) content of the water supply is less than 2500 mg/L. The Tank Failure Warranty does not apply in areas where the TDS exceeds 2500 mg/L.

In areas where the TDS exceeds 600 mg/L, it is possible the magnesium alloy anode (supplied in standard water heaters) may become over-reactive. To alleviate this, a hard water model is recommended, or the magnesium alloy anode should be replaced with an aluminium alloy anode. Aluminium alloy anodes are available from your local Reece Branch.

The pH level of water supply should be between 6.5 to 9.5. Outside of this range, warranty is void.

Water can also be very corrosive or scaling, the measure of this is the saturation index. If the water saturation index is greater than 0.40, an expansion control valve should be fitted. The tank failure warranty does not apply if the saturation index of water is greater than 0.80 or less than -1.0. Please consult Customer Service

- 1300 412 612 (Australia);
- 0800 081 909 or contact your local Reece branch (New Zealand).

PLUMBING CONNECTIONS

Cold Water Connection:

The water heater is intended to be permanently connected to the water supply main, and not connected by a hose-set.

An approved isolating valve, non-return valve, line strainer (optional but recommended) and union must be fitted between the water supply main and a RP $\frac{3}{4}$ " (DN20) socket marked "INLET" at the bottom of the water heater. See the diagram on page 5 for details.

The unused socket marked "INLET" is to be plugged with one of the brass plugs supplied. Ensure that a sealing material is applied to the brass plug to prevent water leaks.

All fittings must be approved by the relevant Authority. Plastic pipes or fittings shall not be used between the isolating valve and the inlet.

Water Supply Pressure:

This water heater is designed for direct connection to water supply pressures of up to 800 kPa.

Where the mains pressure can exceed or fluctuate beyond this pressure, a pressure reducing valve must be fitted in the cold-water inlet supply.

Note for New Zealand, South

Australia and Western Australia: It is a requirement in these locations that an expansion control valve be fitted on the cold water supply line between the non-return valve and the water heater.

Cold Water Connection Diagram:

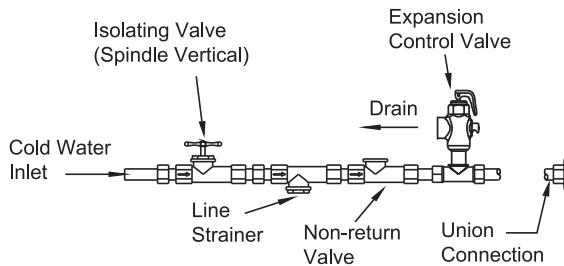

Note: a combined isolating valve/non-return valve/line strainer may be used.

The expansion control valve is only required where local regulations demand, although it is recommended in areas where the water saturation index is greater than 0.40.

FILLING AND DRAINING

Filling the Water Heater:

The water heater must be filled with water before turning on the electrical supply.

1. Open all hot water taps.
2. Open the isolating valve at the cold-water inlet slowly and allow the water heater to fill until water flows through the system.
3. Close each hot water tap after the air is expelled from its line.
4. Open the Pressure & Temperature Relief Valve for approximately 10 seconds by lifting the easing lever on the valve. Confirm water is relieved to waste through the relief valve drain pipe.
5. Lower the lever gently and check it closes correctly.

Draining the Water Heater:

1. Turn off the electricity supply to the water heater.
2. Turn off the cold-water supply to the water heater at the isolating valve.
3. Gently operate the easing lever on the Pressure & Temperature Relief (PTR) Valve to release the pressure in the water heater.
4. Disconnect the cold-water inlet union and attach a drain hose to the water heater.
5. Gently operate the easing lever on the PTR Valve to let air into the water heater and allow water to escape through the hose.

SPECIFICATIONS

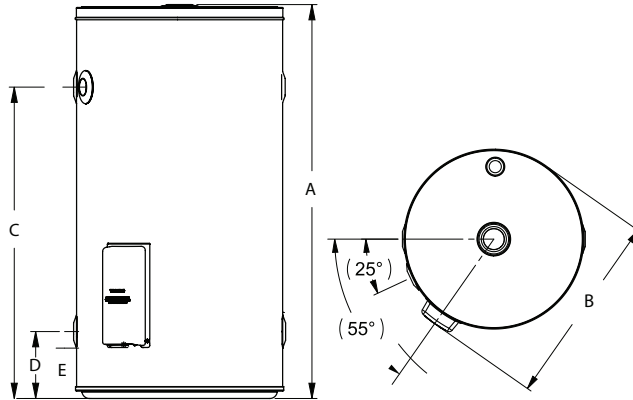

MODEL		80L	125L	160L	250L	315L	400L
Specifications:							
Storage Capacity	Litres	88	130	161	259	321	415
Hot Water Delivery	Litres	80	125	160	250	315	400
Net Weight Empty	kg	41	51	59	72	93	115
Element Size (Single Element)	kW	1.8, 2.4, 3.0	1.8, 2.4, 3.0	1.8, 2.4, 3.0	1.8, 2.4, 3.0	1.8, 2.4, 3.0	2.4, 3.0
Relief Valve Pressure	kPa	1,000	1,000	1,000	1,000	1,000	1,000
Relief Valve Temperature	°C	99	99	99	99	99	99
Relief Valve Power Rating	kW	10	10	10	10	10	10
Nominal Dimensions:							
Total Height (A)	mm	925	1090	1315	1445	1765	1705
Diameter (B)	mm	490	530	530	620	620	705
Outlet Height (C)	mm	735	865	1095	1210	1530	1445
Inlet Height (D)	mm	160	190	190	195	195	220
Element Cable Entry (E)	mm	126	135	135	140	143	168
Connections	Deg	90°	90°	90°	90°	90°	90°

ELECTRICAL CONNECTION

General:

This water heater is designed for single phase 230 - 240V A.C. supply only. The electrical connection must comply with Local Supply Authority Regulations and AS/NZS 3000.

Pre-Wired Models:

Water heaters with the letter "P" at the end of their model number are factory fitted with a power supply cord. These water heaters may be plugged into a standard general purpose power outlet.

If the power supply cord is damaged, it must be replaced by the manufacturer, an authorised service agent or a similarly qualified person in order to avoid a hazard.

"Hard Wired" Models:

Water heaters without the letter "P" at the end of their model number are not factory fitted with a power cord.

Connection of the electrical wiring must only be carried out by a licensed tradesperson.

Connections are made at the terminal block under the water heater electrical cover. A means for disconnection must be incorporated in the fixed wiring in accordance with the Wiring Rules.

DO NOT REMOVE ELECTRICAL COVER AS THERE IS LIVE POWER UNDER THE COVER.

Removing the Electrical Cover:

Before removing the electrical cover, ensure the electrical power supply is safely isolated. The power supply to

the water heater must be completely disconnected at the meter board before attempting to open the electrical cover. Turning off the water heater from the App is not sufficient to prevent exposure to live parts and potential electrocution.

The electrical cover is removed by undoing the two screws at the bottom of the cover and sliding the cover downwards to disengage the top edge.

WARNING:



Pair or reset Wi-Fi by turning OFF the power at the isolation switch or meter box and turning it back ON.

The water heater will be in pairing mode for 5 minutes only.

Refer to page 12 for instructions.

Status Lights:

The status lights in the Wi-Fi module can be interpreted using the following legend.

Green LED: ON/OFF = ECO Mode ON/OFF

Red LED: ON/OFF = Element ON/OFF

Blue LED: (ON/OFF/ BLINK) = Connected to Wi-Fi/OFF, disconnected from Wi-Fi / Pairing Mode active

Connections:

The cable entry is a pre-punched hole designed to accept a 20 mm conduit gland. It is located adjacent to the terminal block.

ELECTRICAL CONNECTION

To prevent damage to the wiring, the cable entry must be fitted with a gland prior to feeding the wiring through the hole. Ensure the conduit entry is sealed correctly.

Connect the active and neutral wires to the terminal block and the earth wire to the earth tab (located on the right-hand side). Excess wire is not to be looped close to the thermostat or tank.

Replacing the Electrical Cover:

1. Slide the cover up, ensuring the top edge engages under the case.
2. Swing the cover down until the bottom edge contacts the case. Ensure the terminal block mounting plate is below the pins located inside the cover.
3. Refit & tighten both screws in the cover.

Ensure the water heater is filled with water before turning on the electricity supply.

WARNING

The water heater must not be wired to an excess PV diverter or to the output of other power modulation devices that may not provide a sinusoidal 230-240V - 50Hz power supply.



Ensure the Thermostat dial (white) is set to OPK/Wi-Fi.

All other thermostat dial settings are not recommended and may not sync with the app.

WIRING DIAGRAM

MODELS **NOT** PRE-WIRED WITH A FLEXIBLE LEAD
 (FITTED WITH A TERMINAL BLOCK)

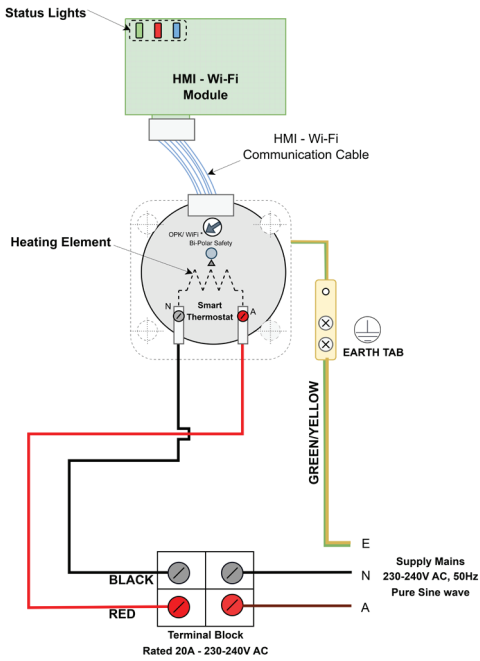

MODELS PRE-WIRED WITH A FLEXIBLE LEAD
 (MODEL NUMBER HAS 'P' SUFFIX)

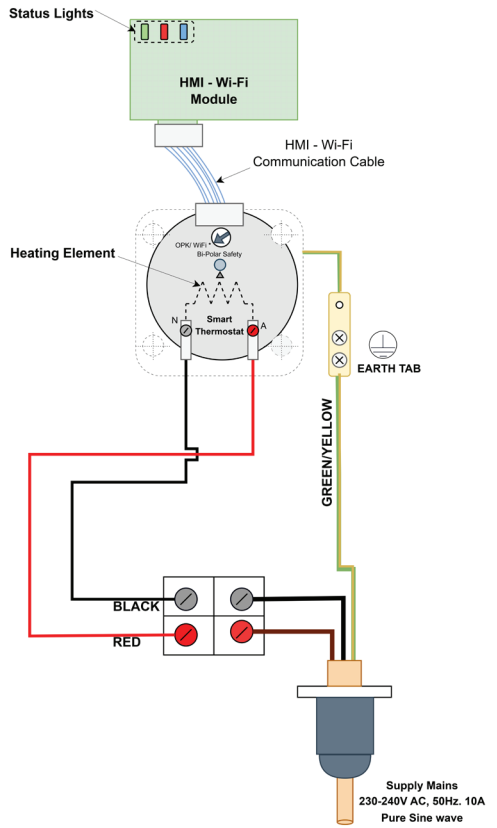

WATER HEATER MODES

The Thermann Smart Electric storage water heater can be programmed to run in various modes based on the requirements of the user. The following are the various modes and features available for the water heater. These modes are only available through the Thermann Control app.

The water heating system heats water to the specified temperature target set through the app.

The displayed temperature on the home screen refreshes every 20 - 30 seconds providing a live update on the water temperature in the tank.

The sensor is located at the bottom of the tank to ensure that the whole tank is heated before turning off the heating element.

When heating is enabled, the water heater will only begin reheating once the water temperature falls at least 8°C below the selected setpoint.

You may notice that shortly after a heating cycle finishes, the displayed water temperature drops by 2-3°C. This is normal as the temperature sensor is located at the bottom of the tank and the hotter water naturally rises to the top of the tank due to convection currents, causing a brief change in the measured temperature.

The recovery rate of the water heater may vary based on the element's power rating, tank capacity, water usage and ambient temperature. And hence the hours allocated in schedule mode will depend on the tank capacity and usage.

MODES

Manual

This is the default mode for the water heater and will heat the tank to 65°C, just like a conventional electric storage water heater. In this mode, the user can set the temperature by single degree increments from a recommended minimum of 50°C up to a maximum of 70°C. A higher stored water temperature will provide more hot water but consume more energy.

When connected through the app, to overwrite the default manual mode temperature set point, select manual mode, set a new value and change to Eco mode and then back to manual mode. The new default set point is saved.

Warning: If you set the temperature too low, whilst you maximise savings, you may run out of hot water.

Holiday

This mode can be used when the water heater is not expected to be used for a long duration. This will help to save energy for periods of planned non-use. A return date can be set to turn on the water heater on the day prior to your return ensuring hot water will be available. An anti-bacterial cycle will run each week in holiday mode to ensure that the water is stored hygienically. The user will be notified when the water heater starts the anti-bacterial cycle. Please note that notification permissions must be granted through the Thermann Control App for this feature to work.

WATER HEATER MODES

If the water heater is not used for two weeks or more, a quantity of hydrogen may accumulate. Refer page i for safe displacement.

Schedule

The Thermann Smart Electric water heater can be scheduled to operate only during specified times of the day. This mode can be used to program the water heater so its operation coincides with economical Time of Use (TOU) tariff periods or to consume PV solar generation, maximising your savings.

Please note that scheduling the water heater to only heat at particular times may increase the risk of running out of hot water. If you are regularly running out of hot water, you will need to allocate additional hours for heating.

Any changes to scheduling must be saved, or the water heater will default to previously programmed settings.

Note: Ensure a schedule is set for each day you want the water heater to operate.

Eco

In this mode, the Thermann Smart Electric water heater will learn your hot water usage pattern and automatically adjust the allotted heating times and the temperature set points to save energy and lower usage charges. You cannot manually adjust the temperature in this mode.

Turn On/Off

The water heater can be turned off using the power button on the App whilst still being connected to a power supply. The antibacterial cycle will

remain active. The water heater needs to be turned on using the same button from within the App. Heaters in Holiday or Turn OFF mode may still allow the users to participate in demand response control tariffs if permission have been granted. For planned vacations it is recommended to use holiday mode.

Antibacterial Cycle

The antibacterial cycle is to prevent legionella formation in the water. The cycle is triggered to ensure that the stored water is heated more than 62°C continuously for 32 minutes every 7 days if the stored water temperature was consistently below 62°C.

The software algorithm for antibacterial cycle may be optimised for later models without prior notice whilst still being compliant in accordance with the latest version of Australian Standard AS-3498 or applicable plumbing codes.

This cycle will happen regardless of the mode the water heater is set to. The cycle may commence on the 3rd day of the first week that the water heater has been powered ON, if the temperature of the stored water has not complied with the requirements of the standard.

If the heater is compliant with the requirements, the antibacterial cycle will not activate.

The water heater may (if necessary) do an initial antibacterial heating cycle, within few hours of power supply is turned ON or restored.

Warning - 1: Please note that turning off mains power and turning it back on will not change any saved settings. The

WATER HEATER MODES

settings can only be changed through the Thermann Control App.

Warning - 2: The power supply to the water heater must be completely disconnected at the isolation switch or meter box before attempting to open the element cover. Turning off the water heater from the App is not sufficient to prevent exposure to live parts and potential electrocution.

See the table below for a broad guideline on the best mode for you. For a more customised advice about modes, temperature settings and schedules, scan the QR code on the next page.

MODES	Which mode do I use?
Manual	Use Manual mode if your water heater is on a “controlled load” (only getting power supply to the heater at particular times of the day, typically at night). You could save on electricity cost by running the water heater at lower temperatures down to 50°C.
Schedule	Use Schedule mode if you have Solar PV or if you are on a “Time of Use” tariff. A “Time of Use” tariff is when you have different tariffs at different times of the day.
Eco	Use Eco mode if you don't have a solar PV system and you are on a flat rate tariff. It will learn your usage and optimise its operation.
Holiday	The holiday mode can be used when hot water is not expected to be used for extended periods.

THERMANN CONTROL APP

When setting up the Thermann Control App, you will have a 5 minute Wi-Fi pairing window when first powering on the water heater.

If this is not completed within the first 5 minutes, the water heater power supply must be turned off and back on to restart the 5 minute Wi-Fi pairing window.

The Thermann Control App gives you unprecedented control over the operation of your water heater.

To download the App, access the Thermann Optimisation Calculator to discover how to get the best out of your water heater, scan the QR code below.

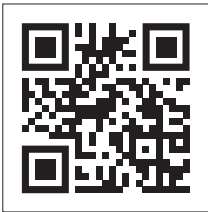

Alternatively, you can search for “Thermann Control” in the App Store or Google Play Store.

After downloading, follow the steps described in the setup guide.

IMPORTANT - your Wi-Fi signal must be able to be received at the water heater location. It is possible that you may require Wi-Fi extenders. If you can't receive Wi-Fi at the water heater's location, you may be able to connect with a temporary hot spot, but you will only be able to control the heater when network is available and may not benefit from

the full functionality. Full functionality requires a Wi-Fi connection at the water heater's location.

WARNING: Please ensure that the water heater is filled with water before attempting to turn the water heater on and also prior to setting up smart features on your mobile device.

Minimum requirements for Wi-Fi connectivity

- Power supply to the water heater.
- Strong Wi-Fi network in 2.4GHz bandwidth available for connection.
- Reliable internet connectivity and speed from the internet service provider.
- Operating system requirements on the mobile device - Android version 5.0 or Later, IOS version - 14.0 or later.

See the Owner's Guide for troubleshooting.

Setup guide

1. Install and open the “Thermann Control” App and select “CREATE ACCOUNT”. Enter your email address and set the password for your user account. When prompted, please grant notification permission.

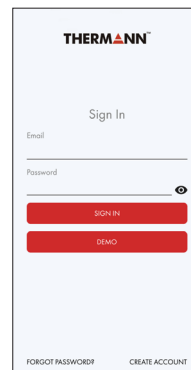

The screenshot shows the Thermann Control app's sign-in interface. At the top, the Thermann logo is displayed. Below it, the text "Sign In" is centered. There are two input fields: "Email" and "Password". The "Password" field has a small eye icon to its right. Below the input fields are two red buttons: "SIGN IN" and "DEMO". At the bottom of the screen, there are two links: "FORGOT PASSWORD?" and "CREATE ACCOUNT".

THERMANN CONTROL APP

2. Review & agree to the App Terms & Conditions, Privacy Policy and select “CREATE ACCOUNT”. An email with an activation link will be sent to your registered email address.

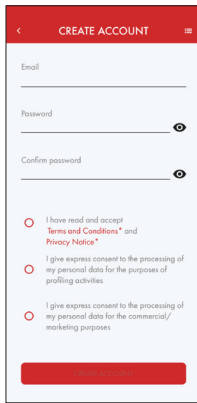

3. Verify your account through the email verification link received.

4. Once verified, go to settings or notification bar on your mobile device and enable Wi-Fi, Bluetooth and Location.

5. Open the Thermann Control App and enter your credentials and select “SIGN IN”.

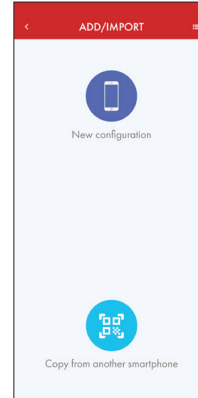

6. Select “New Configuration” for initial pairing. Choose the 2.4GHz Wi-Fi network you want the water heater to be added to and enter the password. Name your water heater and select country and region.

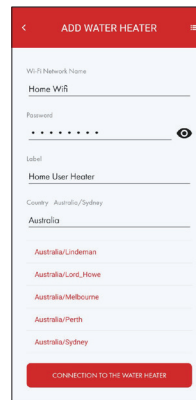

Poor Wi-Fi Signal:

In the instance of poor Wi-Fi signal, refer to page 21 for instructions to set up a temporary hotspot

THERMANN CONTROL APP

WARNING: Please ensure that the water heater is filled with water before attempting to turn the water heater on and before setting up smart features on your mobile device.

7. Locate the isolating switch to the water heater and turn it ON. Please note that the initial power ON to the water heater will trigger a temporary Wi-Fi pairing mode which will remain active for only 5 minutes.
8. Check all the details entered in the "ADD WATER HEATER" page and select "CONNECTION TO THE WATER HEATER".

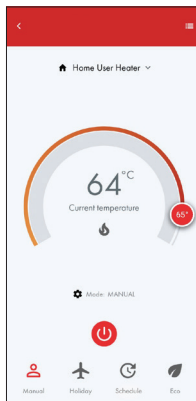

The water heater will be paired to the Wi-Fi network and added to your user account. This may take several minutes. Please ensure that the water heater is paired within the 5-minute pairing window. Any successive power OFF and ON will cause the water heater to enter pairing mode. However, it will

revert to your saved network if no input has been received during the pairing mode. Note, the water heater cannot be controlled during the pairing window.

On successful pairing, the App will default to the home page, displaying a virtual temperature control dial in manual mode.

Note: The water heater must be installed within the Wi-Fi range. A Wi-Fi extender may be required incase of poor signal quality. Pairing may only be completed when the user is close to the water heater.

9. The default setting for the water heater is in manual mode and set to 65°C. The water heater is ready to use or an alternative mode can be selected. Any changes in the modes or settings can be done remotely provided you have internet connectivity and access to your user account.

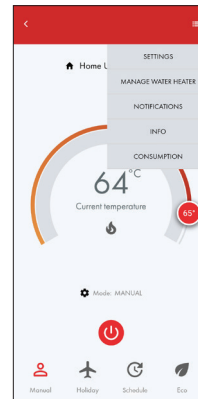

THERMANN CONTROL APP

Additional Features; View Energy Use and Running Costs

10. (Optional) Go to the settings menu and select “CONSUMPTION”. Select settings “SET PRICE/ POWER”.

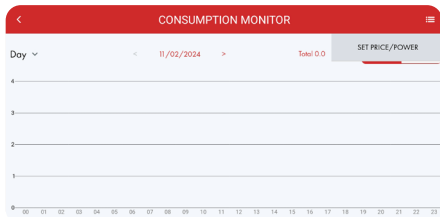

11. Enter price per KWh as per your bill from your electricity retailer, and enter the power of the water heater in watts (e.g. 3.0kW equates to 3000 watts). Power rating information can be found on the data label on the side of the water heater.



The consumption monitor may take several hours to update the displayed data logged and display graphs for consumption and price.

Note: Cost per KWh is in dollars so 25 cents would be 0.25.

Additional Features; Sharing Accounts for Multiple Users

12. If you need to share the control of the water heater to another device(s), download and install the Thermann Control App on the secondary device and follow steps 1 to 5. When prompted, select copy from smart phone.

Now, go to settings on the primary device and select “MANAGE WATER HEATER”. Then select the “SHARE” button next to your listed water heater which you wish to share. A QR code will appear on the screen of your primary device which can be scanned by the secondary device to establish connection.

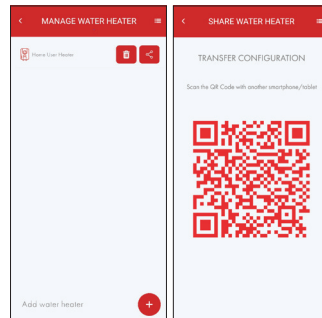

Warning: By sharing connection to a new device, you are giving full consent to manage your water heater. The manufacturer is not responsible for notifying the primary user if any change occurs in settings or modes of the water heater that may arise from shared access.

Note: If you repair the water heater to a new account/user, any previous linked users will be removed and the water heater will only be accessible to the latest user who has paired.

THERMANN CONTROL APP

Additional Features; Adding Additional Water Heaters

13. Multiple water heaters can also be added to your user account and managed under one account.

Open the “Thermann Control App”, sign-in to your user account and go to the settings menu and select “MANAGE WATER HEATER”.

Select “ADD WATER HEATER +” to add a new water heater. Follow pairing procedure steps from 6-9.

Additional Features; Scheduling Your Water Heater

14. When in Scheduling mode, you can set the times of day to heat the water.

You must set the schedule for each day in the App. It does not copy the schedule across.

It won't heat if a schedule is not set.

Change of Phone / Wi-Fi Router

If you have lost access to your mobile device or installed a new Wi-Fi router, you can initiate the pairing process by following steps 1-9.

Alternatively, settings from an existing user who is already connected can be shared with a secondary user.

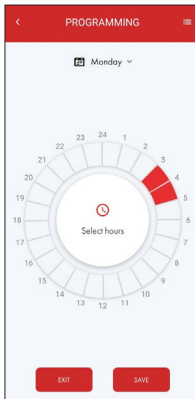
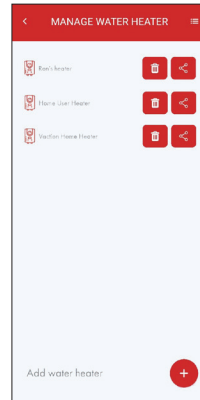

ADDITIONAL FEATURES

T-Comfort Auto Setting

In the Schedule mode, the user can set a minimum water temperature value that they are comfortable with.

The Thermann Smart Electric water heater will automatically heat to this temperature even if it is outside of the scheduled run time. This will ensure that the water temperature does not drop below the minimum setting when heating is not scheduled.

The T-Comfort setting can be accessed from the settings menu in the app. The adjustable range of T-Comfort auto is from 10°C to the set point temperature displayed in the main temperature adjustment dial of the Schedule mode.

T-Comfort Auto setting has no effect on Holiday mode or Turn OFF mode. Please note that this setting will interfere with the Schedule if the water temperature drops more than 8°C below the T-Comfort set point. If the user wishes to minimise interference with the Schedule, set the T-Comfort value to a minimum of 10°C.

Frost Protection mode

All Thermann Smart Electric water heaters are equipped with a frost protection feature to prevent the heater from freezing up in extremely cold weather conditions.

The water heater must have a power supply for this feature to work. If the water temperature drops to 5°C, the water heater will start heating to warm up the water to 16°C.

This feature ensures that the water heater is protected from freeze damage, even in the Holiday or Turn OFF mode.

SYSTEM MAINTENANCE

Regular servicing will help to extend the life of the water heater, and keep it operating safely and efficiently.

Your water heater warranty is not conditional on completing the regular servicing recommended in this manual.

The conditions applying to your water heater warranty are set out on page 24 of this manual.

Six Month Service:

This service may be carried out by the owner.

1. Stand clear of the Pressure & Temperature Relief (PTR) Valve drain pipe outlet.
2. Open the PTR Valve for approximately 10 seconds by lifting the easing lever on the valve. Confirm water discharges to waste through the drain pipe.
3. Lower the easing lever gently and check it closes correctly.
4. Repeat the above process for the expansion control valve (if installed).

Other than this, personally inspecting or servicing any part of the water heater is not recommended.

Five Year Service:

This service should only be carried out by a licensed tradesperson.

In locations where the water has Total Dissolved Solids (TDS) exceeding 600mg/L, this service is recommended every 3 years.

This service should include the following:

- Replace the PTR Valve.
- Replace the anode.
- Inspect and flush the expansion control valve (if installed).
- Drain and flush the water heater.
- Inspect the condition of the electrical conduit and the water heater electrical cover. Replace any damaged components.

Drain and flush the water heater.

Replacement parts are available from your local Reece branch.

CONSIDERING A SERVICE CALL?

It is recommended that the following points be reviewed before making a service call:

No Hot Water:

Check the App to ensure that the heater is not set on Holiday mode, Schedule or Turned Off in the App.

For the water heater to heat, and the App to be available for pairing, ensure that power is available to the unit. Check that the power supply breaker has not tripped, or if your water heater is on a timed tariff (such as off-peak), that power is currently available.

High Energy Bills or Insufficient Hot Water:

- Often the hot water usage of showers, washing machines and dishwashers can be under estimated. Review these appliances to determine if the daily usage is greater than the capability of the water heater.
- If necessary, check the shower flow rates with a bucket, measuring the amount of water used over a period of time. If it is not possible to adjust water usage patterns, an inexpensive flow control valve can easily be fitted to the shower outlet.
- Is the water heater the correct size for the requirements? Sizing details are available from your Reece branch.

- Is there a leaking hot water pipe or dripping hot water tap? A small leak can waste a large quantity of hot water. Replace faulty tap washers and arrange for your plumber to rectify any leaking pipe work.
- Is the Pressure & Temperature Relief Valve discharging too much water? See below.

Continuous Trickle of Water from Pressure & Temperature Relief (PTR) Valve:

This is most likely due to a build up of foreign matter. In this case, try gently raising the easing lever on the PTR Valve for a few seconds, then release gently.

This may dislodge a small particle of foreign matter and rectify the fault.

Water Discharge from PTR Valve:

It is not unusual for a small quantity of water to discharge during the heating of water in the storage tank. The amount of discharge will depend on hot water usage and the size of the storage tank.

As a guide, it will discharge about 2% of the volume of the water heated.

Continuous leakage of water from the PTR Valve may indicate a problem with the water heater. Turn off the water heater and contact Customer Service

- 1300 412 612 (Australia);
- 0800 081 909 or contact your local Reece branch (New Zealand).

CONSIDERING A SERVICE CALL?

Error Detection using Thermann Control App:

Check the Thermann Control App to ensure the water heater is in an appropriate heating mode, and for any indication of errors. The Thermann Control App will indicate an error if the water heater is continuously in operation for more than 24 hours. It will also indicate other errors like a sensor failure.

The Thermann Control App will notify the user when the antibacterial cycle

commences, should it be required. This occurs once a week when the water heater has power supply to it irrespective of whether it is set to ON or OFF in the App or in Holiday mode. (Note: App notification will only work if the corresponding permission has been enabled on your phone).

Following a power outage, when the water heater turns back 'ON', it may take up to 10 minutes to re-establish the saved Wi-Fi network.

TYPE	CODE LABEL	ERROR CODE DESCRIPTION	TROUBLESHOOT
ERROR	NOTIFY_NTC	E2 - High NTC probe : short circuit E2 - High NTC probe : open circuit E2 - Low NTC probe : short circuit E2 - Low NTC probe : open circuit E3 - NTC probes : temperatures gap > 50°C	<ol style="list-style-type: none"> 1. At the isolation switch/ meter box, switch OFF and back ON again. 2. If the problem occurs again, contact Customer Service.
WARNING	NOTIFY_LOW_HEATING_RATE	E4 - Water heater temperature : low heating rate with resistance ON (The heating element will continue to heat when this warning is present)	<ol style="list-style-type: none"> 1. Check if all the taps using hot water are closed. 2. If connected to a ringmain, the warning will automatically reset once the temperature rises by more than 2 degrees in 2 hours. 3. At the isolation switch/ meter box, switch OFF and back ON again. 4. If the warning does not reset, contact Customer Service.
NOTIFICATION	NOTIFY_OVERTEMPERATURE	I1 - High NTC probe : temperature > 95°C	Contact Customer Service.
NOTIFICATION	NOTIFY_ANTIBACTERIAL	I2 - The anti-bacterial cycle has been started I3 - The anti-bacterial cycle has been completed.	No action required. Normal operation. Anti-bacterial cycle to ensure hygiene.

CONSIDERING A SERVICE CALL?

Minimum requirements for Wi-Fi connectivity

- Availability of power supply to the water heater.
- Strong Wi-Fi network in 2.4GHz bandwidth available for connection.
- Reliable internet connectivity and speed from the internet service provider.
- Operating system requirements on the mobile device - Android version 5.0 or Later, IOS version - 14.0 or later.

Poor Wi-Fi Signal

In case of poor signal quality, it is recommended to install a Wi-Fi extender. Also ensure that the Wi-Fi extender is 2.4GHz network enabled and has sufficient range to reach the water heater location.

If a Wi-Fi network is temporarily unavailable and you are needing to program a setting on your water heater, a secondary device will be required. The secondary device can be used to create a temporary hotspot that will act as a Wi-Fi modem.

Note: This is only a temporary solution while you wait for a Wi-Fi extender. Remote monitoring and management of the water heater is subjected to availability of mobile data and Wi-Fi hotspot network connection (2.4GHz bandwidth) from the secondary device.

Please follow the alternate procedure for pairing.

Step 1: Follow steps 1 to 5 (on pages 12 & 13) in the set-up guide using the primary device you wish to use to control the water heater.

Step 2: Turn on mobile data on the secondary device (hotspot network phone), then turn on mobile hotspot.

Note: For iOS users (secondary device / hotspot device), maximize compatibility must be enabled in the Personal Hotspot settings before turning on the hotspot network. The water heater will not pair to a hotspot network on an iOS platform with this feature disabled.

Step 3: On the primary mobile device, go to setting-> Wi-Fi. Then select the new hotspot network that has been created by the secondary device. Enter the password and connect to this network.

Step 4: Once the primary device has connectivity to the secondary devices hotspot network, follow steps 6 to 9 (on pages 13 & 14).

Step 5: Change the water heater modes or settings on the primary device as required. If in Schedule mode, select the desired hours of operation and save the settings. Saving the settings may take a few minutes as the internet connection and Wi-Fi hotspot must remain turned on during this period.

App Error Messages

If you see the error message "Read only mode" during the initial connection, it means the thermostat

CONSIDERING A SERVICE CALL?

dial is not set to its factory position. The installing plumber must check if the thermostat dial is correctly positioned. Factory defaults are OPK/Wi-Fi. If the issue remains unresolved, please contact Customer Service. If a message appears on the home page, "I2 -The anti-bacterial cycle started". This is normal operation of the water heater & the app will prevent any change to the mode or sets points when the anti-bacterial cycle is active. This is not a fault of the app. The water heater will return to the previous working mode & setting once compliance is achieved.

If the app doesn't change modes, save settings, or if the settings are frozen and don't update while heating, there may be a Wi-Fi connection problem between your water heater and the network. Try removing the heater from the "Manage water heater" dropdown menu in the app and pair it as a new device. If this does not fix the problem, contact Customer Service.

If the water heater detects that the electronic components are experiencing high ambient temperature inside the element cover due to extreme sunlight hitting the cover, it may pause heating to prevent overheating to protect the components and extend the life of the water heater. This is normal operation, and the water heater will resume heating once the ambient is within safe limits.

Why does the displayed water temperature drop after the heating cycle finishes?

When the heating cycle finishes, you may notice the displayed temperature drop by 2–3°C. This is normal, as hot water moves within the tank and mixes with cooler water.

Troubleshooting Wi-Fi Connections:

Water heaters need two main aspects to ensure trouble free operation.

Power Supply: Heater requires power supply available during the time of pairing. Check for controlled load on your electricity bill, manual timers or faulty power supply switch that may cause interruptions in the power supply. This causes a water heater detection error.

Reliable Wi-Fi network in 2.4GHz: The Wi-Fi signal must be strong near the water heater location & have correct bandwidth.

If pairing fails due to a timeout without any error message, or if you lose connection without changing network settings, you might see "Please Check Wi-Fi connection" on the home page. This is likely because of network incompatibility or dropouts, especially when the heater is forced to use a dual-band or 5GHz network, or if your router blocks the connection. It may also indicate that the connection was unsuccessful due the wrong password. During minor disconnections, the heater may fail to reconnect if the router assigns it to a different channel

CONSIDERING A SERVICE CALL?

width or 5Ghz. Watch out for settings such as band steer or smart connect on your router. Wi-Fi dongles may also force unexpected disconnections.

The heater's Wi-Fi works best on a 2.4GHz network with 20MHz channel width for minimal interference. You can try creating a 2.4GHz guest network and pair to the Guest network, if your router has that function. You can also split your Wi-Fi into separate 2.4GHz and 5GHz bands and use only 2.4GHz for the heater, provided this won't disrupt connection of other smart devices. These steps should help ensure a stable and compatible connection. The network settings for your specific network device can be configured correctly by reaching out to the device manufacturer's support.

Note: Some routers might block the heater from reconnecting. Check your router's list of blocked devices and make sure to unblock or whitelist the device, usually labelled as "SMART ELECTRIC" or "ESPRESSIF".

The water heater cannot connect to Wi-Fi networks that require a captive portal (where you need to accept terms or sign in) and cannot connect to open, unsecured networks (those without a password).

If after checking the above points, the problem has not been identified, please consult Customer Service:

- ***1300 412 612 (Australia);***
- ***0800 081 909 or contact your local Reece branch (New Zealand)***

If a Service Agent is required to attend site, a charge will be payable.

WARRANTY

Thermann Smart Electric Water Heater - Warranty Summary:

Your water heater is specified with a warranty as set out in the table below.

The fault must appear within the defined time period, which commences from the date of installation (or manufacturing date of the unit if proof of the date of installation is not available) in order to be covered.

Thermann Smart Electric Water Heater Warranty

Thermann Smart Electric Water Heater Warranty		Warranty
Single Family Dwelling	Tank	10 years
	Parts ¹	3 years
	Other Parts ² & Labour	1 year
All Other Applications	Tank	3 years
	Parts & Labour	1 year

(1) Three years parts warranty applies to the Wi-Fi module (chip set), connecting cable, thermostat and element. (2) All other parts including but not limited to the PTR valve and anode, are covered by a 1 year parts warranty.

The benefits provided to you by this warranty are in addition to any other rights and remedies available to you under the Australian Consumer Law or the Consumer Guarantees Act 1993 (New Zealand).

Parts¹ Warranty:

Dux Manufacturing Limited ("Dux") warrants against defects in the water heater arising from faulty materials or workmanship.

During the period (as specified in the table above), Dux will repair or replace defined failed components¹ free of charge. Installation and other labour costs are the responsibility of the owner, if the water heater is outside the specified labour warranty period.

Other Parts² and Labour Warranty:

Dux Manufacturing Limited ("Dux") warrants against defects in the water heater arising from faulty materials or workmanship.

During the period (as specified in the table above), Dux will repair or replace the defined failed component² free of charge including reasonable labour costs incurred during normal business working hours.

Parts and Labour Warranty:

Dux Manufacturing Limited ("Dux") warrants against defects in the water heater arising from faulty materials or workmanship.

During the period (as specified in the table above), Dux will repair or replace any failed component, or where necessary, in the absolute discretion of Dux, replace the water heater, free of charge including reasonable labour costs incurred during normal business working hours.

WARRANTY

Tank Failure Warranty:

Dux warrants against failure of the storage tank, in accordance with its application (as specified in the table above). Conditions apply.

Installation and other labour costs are the responsibility of the owner if the water heater is outside the labour warranty period.

Warranty Conditions:

The warranty only applies to the water heater itself and the components supplied with the water heater by Dux. The warranty does not cover components supplied by others, including the installer.

The tank failure warranty does not apply if the water heater has been connected to a water supply where the Total Dissolved Solids content is greater than 2500mg/L and/or if the saturation index of water is greater than 0.80 or less than -1.0.

These warranties do not apply to defects that are a result of, without limitation, the following:

- failure to install the water heater in accordance with the installation instructions or statutory requirements;
- faulty plumbing or water supply including excessive pressure;
- faulty or improper power supply: including damage caused by improper power supply from power control or modulating

devices such as excess PV-diverters which do not provide a continuous sinusoidal 230-240VAC, 50Hz;

- use of the water heater in a manner contrary to this manual or other instructions provided by Dux;
- if the water pH is less than 6.5 or greater than 9.5;
- alterations or repair of the water heater other than by an accredited and licensed service agent or technician;
- accidental damage or abuse.

If the water heater is installed in a position that does not comply with the installation instructions or statutory requirements, then this warranty does not cover major dismantling or removal of cupboards, doors, walls or special equipment and/or excessive labour, at the determination of Dux, to make the water heater accessible for repair or replacement.

Where the Dux water heater is located outside the metropolitan area of a capital city and is more than 100km from a Dux office or Dux agent, the Owner will be responsible under the warranty for paying the costs of transporting the water heater and or any component in the water heater to and from an approved Dux agent or Dux office (including any insurance associated with that transport),

WARRANTY

or paying the travelling time of an approved Dux agent to and from the owner's premises.

Commencement of Warranty:

The warranty period commences from the date of installation of the water heater. Where proof of the date of installation is not available, the warranty period commences on the date of manufacture of the water heater. This is shown on the compliance plate on the outside of the water heater.

The replacement of the water heater, or a component of it, under this warranty does not change the warranty commencement date. The original commencement date continues to apply.

Exclusion and Limitation of Liability:

In addition to any other provisions set out in this document and to the maximum extent permitted by any applicable law or regulation, Dux will not be liable for any claim:

1. for consequential loss to any property arising directly or indirectly out of or connected to the supply or installation of the water heater. This includes but is not limited to furnishings, carpets, foundations, housing effects and buildings.
2. for any direct or indirect economic or financial loss of any nature.
3. arising out of or connected to a water heater that has been uninstalled, resold or moved from

its original installation location.

4. arising out of or connected to any misuse, or other use, installation or maintenance that is not in accordance with the procedures and requirements set out in this document.

To the extent permitted by law the liability of Dux shall be limited to the cost of the repair or replacement of the water heater.

The Australian Consumer Law ("ACL"):

Our goods come with guarantees that cannot be excluded under the Australian Consumer Law. You are entitled to a replacement or refund for a major failure and compensation for any other reasonably foreseeable loss or damage. You are also entitled to have the goods repaired or replaced if the goods fail to be of acceptable quality and the failure does not amount to a major failure.

If Dux fails to meet a guarantee under the ACL, your remedy for such failure may be limited to any one or more of the following:

- replacement of the water heater;
- repair of the water heater;
- refunding the cost of the water heater;
- payment of the reasonable costs of having the water heater repaired;
- payment in respect of the reduced value of the water heater.

WARRANTY

The Consumer Guarantees Act 1993 (New Zealand):

Our goods come with guarantees that cannot be excluded under the Consumer Guarantees Act 1993 (New Zealand). If the goods fail to comply with the applicable guarantees set out under the Consumer Guarantees Act 1993 (New Zealand) being the guarantee as to acceptable quality, the guarantee as to correspondence with description or the guarantee as to repair and parts, or if the goods fail to comply with any express guarantee given by Dux, then you are entitled to a replacement or refund and for compensation for any other reasonably foreseeable loss or damage.

How to Make a Warranty Claim:

Please consult Customer Service:

- 1300 412 612 (Australia);
- 0800 081 909 or contact your local Reece branch (New Zealand).
- Provide the serial number and model number of the water heater. This can be found on the compliance plate on the outside of the water heater.
- Provide your full name, address and contact number.
- Provide proof of date of installation for warranty to commence from that date, rather than from the date of manufacture. See Commencement of Warranty on page 26.

Please note, if the defect or fault is not covered by the warranty or guarantee, you will be responsible for the costs incurred by the service agent or technician.

Dux service calls can only be scheduled during business hours (AEST) Monday to Friday and are not available on weekends & public holidays.

Contact Details:

Dux Manufacturing Limited
Lackey Road, Moss Vale, NSW, 2577
Australia

1300 412 612 (Australia)

0800 081 909 (New Zealand)

Email: duxaftersales@dux.com.au

HANDOVER TO THE CUSTOMER

Owner's Guide:

Ensure the customer receives the Owner's Guide supplied with the water heater.

Thermann Connect App:

The Thermann Control App gives you unprecedented control over the operation of the water heater. The app is used in conjunction with the water heater to set the operating mode and to deliver maximum running cost savings.

Multiple pre-programmed operating modes, including Schedule, Eco, Manual, and Holiday, can be selected to suit individual hot water requirements.

When setting up the Thermann Control App, you will have a 5 minute Wi-Fi pairing window when first powering on the water heater.

If this is not completed within the first 5 minutes, the water heater power supply must be turned off and back on to restart the 5 minute Wi-Fi pairing window.

Thermann Optimisation Calculator:

Visit www.thermann.com.au or www.reece.com.au or scan the QR code below to access the Thermann Optimisation Calculator. This calculator will recommend which mode may best suit your circumstances.

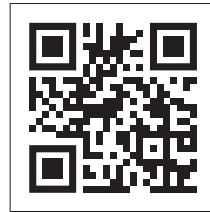

Victorian Installations:

Ensure you provide the customer with a Compliance Certificate as required by the Victorian Building Act (1993). Also ensure you lodge the Compliance Certificate with the VBA within five days of completing the installation.

Packaging:

Dispose of the packaging and other transit protection responsibly using recycling facilities where they exist.

THERMANN™



H0900 Rev. A